

Industry



Agricultural and Construction Vehicles Driving Growth with New Technologies

Sika®



Content

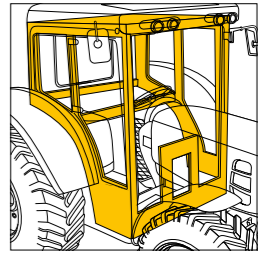

Cabin Bonding and Sealing before Paint_4

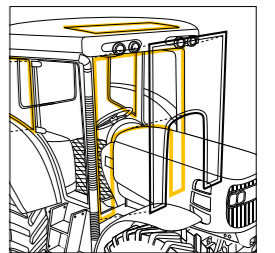

Direct Glazing and Open Joint Sealing_6

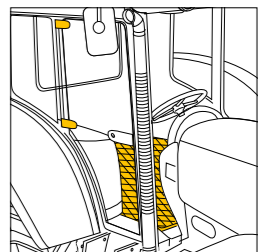

Trim Shop Bonding and Sealing_8

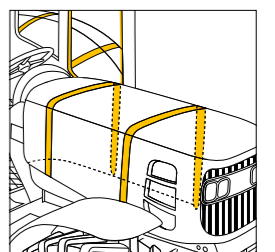

Structural Bonding of Doors and Closures_10

Driving Growth with New Technologies

Agricultural and construction vehicle users across the globe require vehicles capable of withstanding harsh climatic conditions while providing outstanding reliability and greater levels of user comfort. A safe and secure working environment for the vehicle operator is a priority today. In order to meet such challenges, designers must constantly find solutions that enable manufacturers to accelerate their build times, increase vehicle safety / strength and the longevity of the product.

Sika, as the partner to the global agricultural and construction vehicle industry, provides a wide range of state-of-the-art technologies to assist manufacturers in meeting their requirements. We provide specific solutions on our core competencies: Bonding, Sealing, Damping and Reinforcing. As a globally operating company, we are represented in your countries with own subsidiaries, ensuring first-class technical and commercial support, order handling and delivery, from the first concept through the entire life cycle of your vehicle.



Cabin Bonding and Sealing before Paint

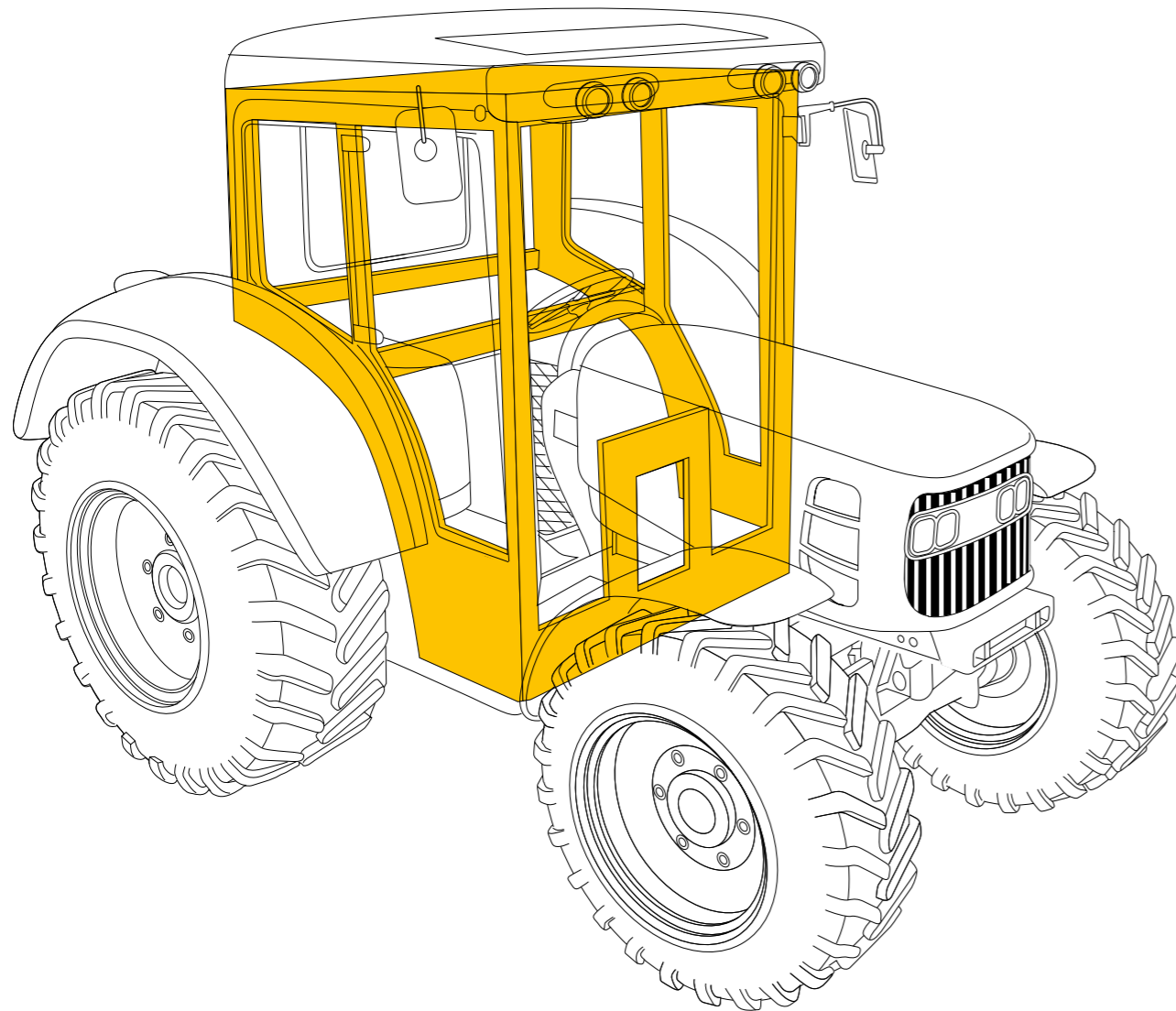

Manufacturers of agricultural and construction vehicles use different processes in the production and assembly of the cabin structure. Corrosion protection and a perfect final paint finish must be completed early in the vehicle assembly process. The vehicle structure should demonstrate high strength and maximum durability in order to ensure optimum operator / user safety.

Sika provides a range of material technologies ideally suited to such challenging and diverse environments. SikaPower® body shop adhesives and sealants are heat-curing products based on one- and two-component polyurethane-epoxy hybrid technology. They are easy to combine with other joining technologies. Flexibility, durability and a reduction in the number of spot welding points are just some of the advantages provided by this sealing and bonding technology. Sikaflex® polyurethane sealants and adhesives provide high-performance elastic assembly and sealing within an easy-to-use one-component formulation for low bake condition. Sikaflex® hot cure (HC) polyurethane adhesives and sealants cure rapidly by exposure to heat in the paint shop. Sika-Fast® two-component adhesives combine low surface preparation and high tensile strength with rapid de-jigging and full cure.



Cabin roof welded and sealed before e-coat



Sealed cabins before paint shop

Why Use Cabin Bonding and Sealing before Paint?

- Enhances component stiffness to facilitate weight reduction and improvements in fuel economy
- Improves component crash resistance to enable improved vehicle safety
- Minimises risk of water leakage
- Reduces noise, vibration and harshness
- Enables use of optimum substrate for each application via elimination of the requirements of weld compatibility

Technological Benefits

- Adhesion to oiled metals without pre-treatment or degreasing
- Excellent ageing and long-term durability
- Wash-out resistance
- Low bake curing to improve object temperature variations
- Solvent and PVC-free
- One- and two-component systems to suit OEM process requirements
- Fast hold and curing time
- Manual or automatic application option

Best Recommended Sika Products

Features and Benefits

Sikaflex®-360 HC
Heat-curing high-performance structural adhesive and seam sealer with a long open and fast curing time

SikaPower®-415 P1
Excellent adhesion on oily substrates; heat cured; excellent seam-sealing properties

SikaPower®-430
Semistructural adhesive with excellent adhesion on oily substrates; heat cured; wash-out resistance; spot-weldable

SikaPower®-490/7
Structural adhesive for spot welding bonding with excellent adhesion on oily substrate, heat-curing and wash-out resistant

SikaFast®-3000 Series
High tensile properties, elasticity and impact resistance; excellent adhesion profile; gap-filling capability

Direct Glazing and Open Joint Sealing

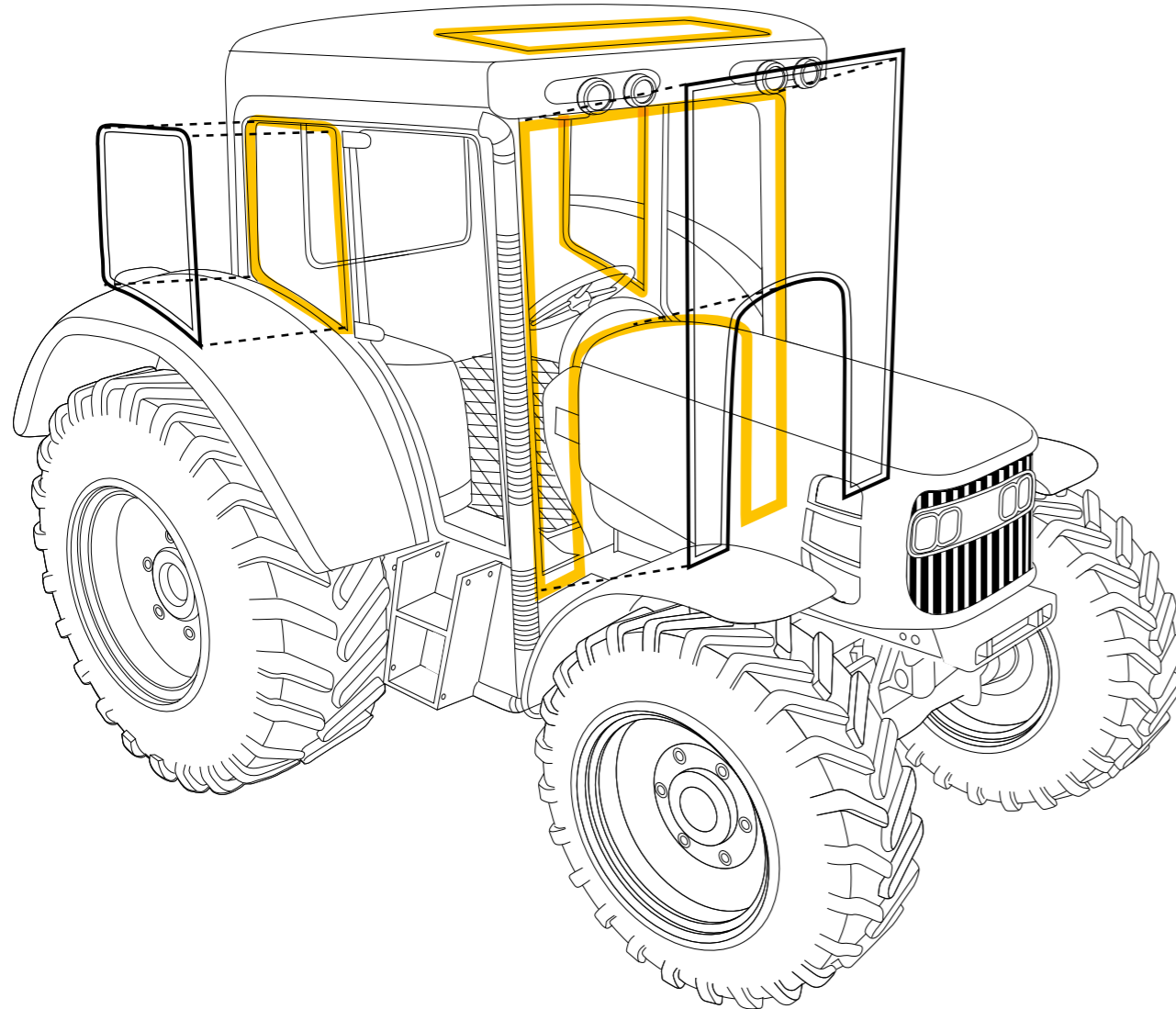

For over 20 years, Sika has been providing agricultural and construction vehicles, bus and coach, automotive, truck and rail OEM assembly lines with adhesive and sealant solutions for sealing and direct glazing. Primerless, manual and automated pre-treatment options are available to fit the needs of a variety of OEM application processes in order to create significant cost savings and manufacturing process simplification.

Sika offers a wide range of adhesive and sealant technologies to suit all direct glazing and sealing applications. Specific Sikaflex® solutions are available to suit cold, warm and hot application processes. Proprietary Sikaflex® materials are capable of retaining the glass in position following installation, allowing for elimination of secondary clips, fixings and tape. Sikaflex® materials can also provide low electrically conductive properties for elimination of galvanic corrosion. The SikaTack®-Plus Booster range provides the ultimate solution for OEM's seeking excellent mechanical properties with the shortest possible full cure time. Unlike traditional two-component systems, this boosted one-component system has the significant benefit of full material cure irrespective of the presence of the accelerator paste, providing enhanced process/quality consistency and security. Sikaflex® PUR-Hybrid technology (STP-technology) combines the performance of traditional Sikaflex® polyurethane systems, but shows additional characteristics such as reduced substrate surface preparation and improved ecological benefits.

Why Direct Glaze?

- Increased body stiffness for enhanced roll-over strength and improved occupant impact protection
- Enhanced aerodynamics versus glazed gasket systems to improve fuel economy and vehicle emissions
- Higher body stiffness to reduce noise, vibration and harshness within the vehicle body

Why Seal?

- Improved acoustic environment (lower noise)
- Watertight seals ensure protection of vital electronic equipment
- More efficient air-conditioning and heating
- Watertight seals ensure durable and long-lasting protection

Technological Benefits

- Sika's tried and tested primerless to glass and paint technology
- Accelerated with Sika® Booster for rapid full cure
- High initial green strength
- Hot and warm applied systems to eliminate secondary clips, fixings and tape
- Improved water and leak resistance
- Simple substrate preparation, very easy to use
- High levels of aesthetic finish achievable

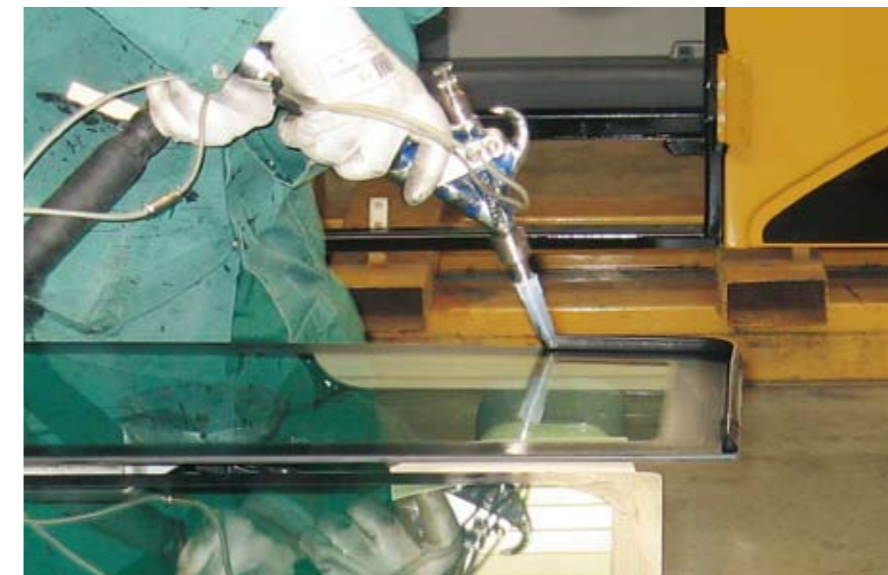

Application of Sikaflex® direct glazing adhesive



Direct glazed cabin after leakage test

Best Recommended Sika Products Features and Benefits

Sikaflex®-222 UV

UV-resistant, ideal for use with organic glass or open joints; easy application; suitable for bonding and sealing; compatible with PC (polycarbonate) and PMMA (polymethylmetacrylate) with proprietary Sika surface preparation system; high elasticity and low modulus

Sikaflex®-250 PC

Warm applied system; high green strength enables reduction in clips, fixings and tape; good tooling behaviour; widely OEM-approved; excellent adhesion characteristics

Sikaflex®-265

Extremely easy to use; suitable for bonding and sealing; large gap-filling capabilities; excellent aesthetics with a smooth surface finish; long open time; UV-stable

Sikaflex®-521 UV

Joint sealant with excellent UV, ageing and weather resistance, reduced substrate surface preparation needed. Solvent and VOC-free

Sikaflex®-555

STP direct glazing adhesive and sealant. Suitable also for open joints

SikaTack®-Plus Booster

Fast curing; 'failsafe' systems cures even in the absence of Sika® Booster Paste; good mechanical properties and adhesion

Trim Shop Bonding and Sealing

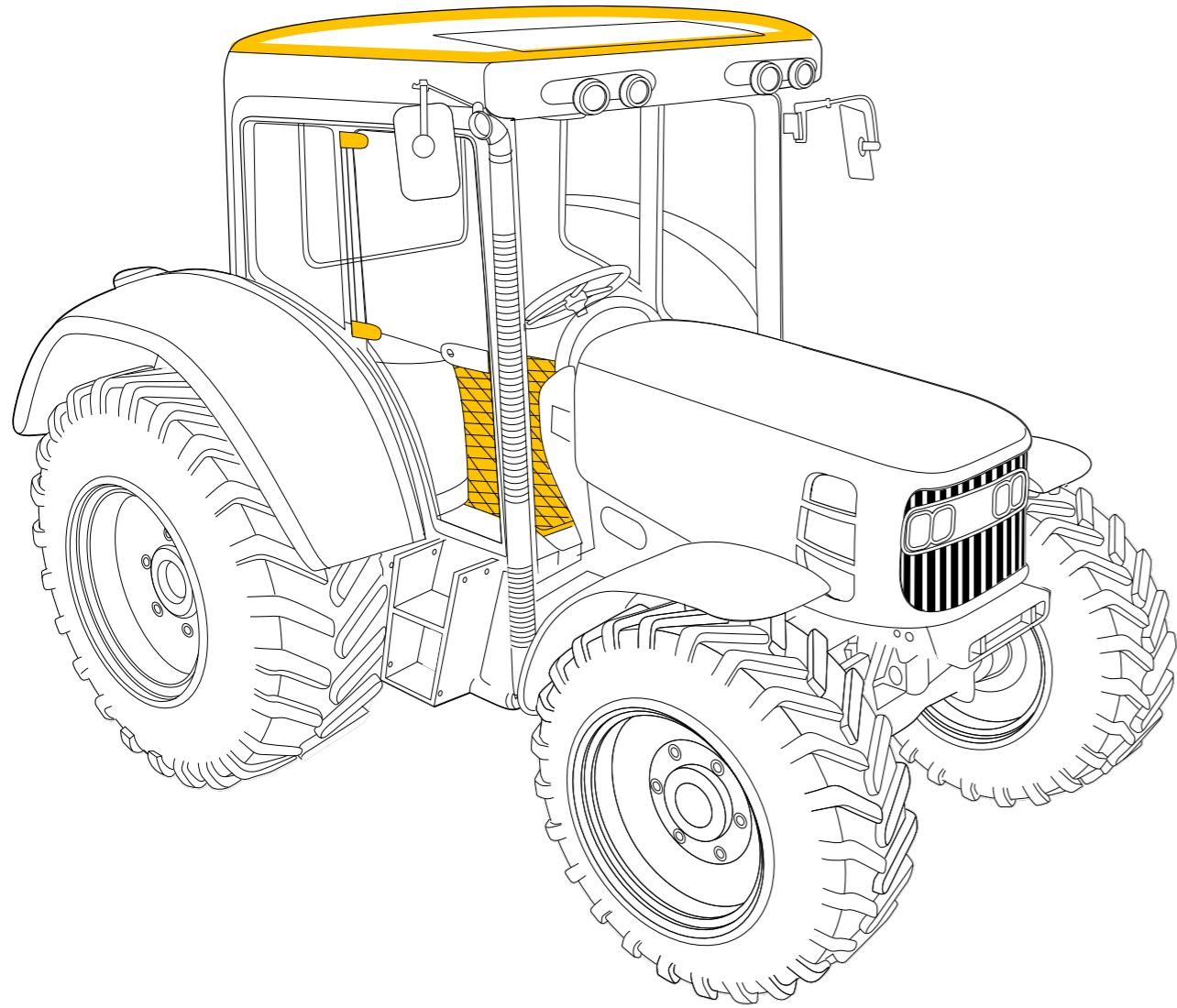

Recent years have seen a dramatic improvement in the styling and appearance of construction and agricultural vehicles. The installation of air-conditioning and higher interior trim levels are clear indicators of such changes in overall vehicle sophistication. The use of thermoset composites and thermoplastic materials is now common for such applications, and has enabled significant improvement in vehicle styling and aerodynamic behaviour.

Sika has formulated a range of materials to exceed customer requirements for this challenging application. Sikaflex® polyurethane (PUR) adhesives and sealants provide a high-performance elastic assembly within an easy-to-use one-component formulation. Sikaflex® PUR-Hybrid, the silan terminated polymer (STP) technology, provides the high performance of Sikaflex® polyurethane systems combined with reduced substrate preparation and improved ecological benefits. SikaFast® two-component acrylic-based structural adhesives provide high strength and excellent impact resistance with low surface preparation. SikaForce® two-component PUR adhesives demonstrate high strength, good flexibility and are capable of curing at room or elevated temperatures.

Why Use Trim Shop Adhesives?

- Adhesive systems absorb vibration, improving interior and exterior vehicle noise levels
- Improved rigidity of the structure
- Can withstand high dynamic stresses
- Bonded assemblies are more able to withstand shock, impact and torsion
- Elimination of contact corrosion

Why Use Trim Shop Sealants?

- Excellent water resistance, due to elimination of holes and drilling required by mechanical fasteners
- Improved acoustic environment (lower noise)
- More efficient air-conditioning and heating

Technological Benefits

- Rapid assembly with high-performance adhesion
- Excellent impact resistance
- Ability to withstand bonded substrates with different CLTE (Coefficient of Linear Thermal Expansion) between thermoset composites and metals
- Bonds well to a wide variety of substrates
- Eliminates mechanical fixation
- Enhanced sound and vibration damping
- Improved water and leak resistance
- Overpaintable



Preformed floor bonded to the steel frame

Best Recommended Sika Products

Features and Benefits

Sikaflex®-221

High-quality multi-purpose sealant and adhesive, suitable for making permanent elastic seals of high adhesive strength

Sikaflex®-250 PC

Warm applied system; high green strength enables reduction in clips, fixings and tape; good tooling behaviour; widely OEM-approved; excellent adhesion characteristics

Sikaflex®-252

Structural assembly adhesive for flexible joints subjected to dynamic stresses

Sikaflex®-254 Booster

Fast curing; 'fail-safe' systems cures even in the absence of Sika® Booster Paste; good mechanical properties and adhesion

Sikaflex®-521 UV

Joint sealant with excellent UV, ageing and weather resistance. Reduced substrate surface preparation needed. Solvent and VOC-free

Sikaflex®-552

UV-stable assembly adhesive for sealing and bonding, excellent adhesion properties, ecology-friendly; suitable also for exterior joints

SikaFast®-3000 Series

High tensile properties, elasticity and impact resistance; excellent adhesion profile; gap-filling capability

SikaFast®-5000 Series

High mechanical properties; fast curing with long open times; excellent adhesion profile; low odour

SikaForce®-7550

Two-component, high-strength elastic assembly adhesive

Structural Bonding of Doors and Closures

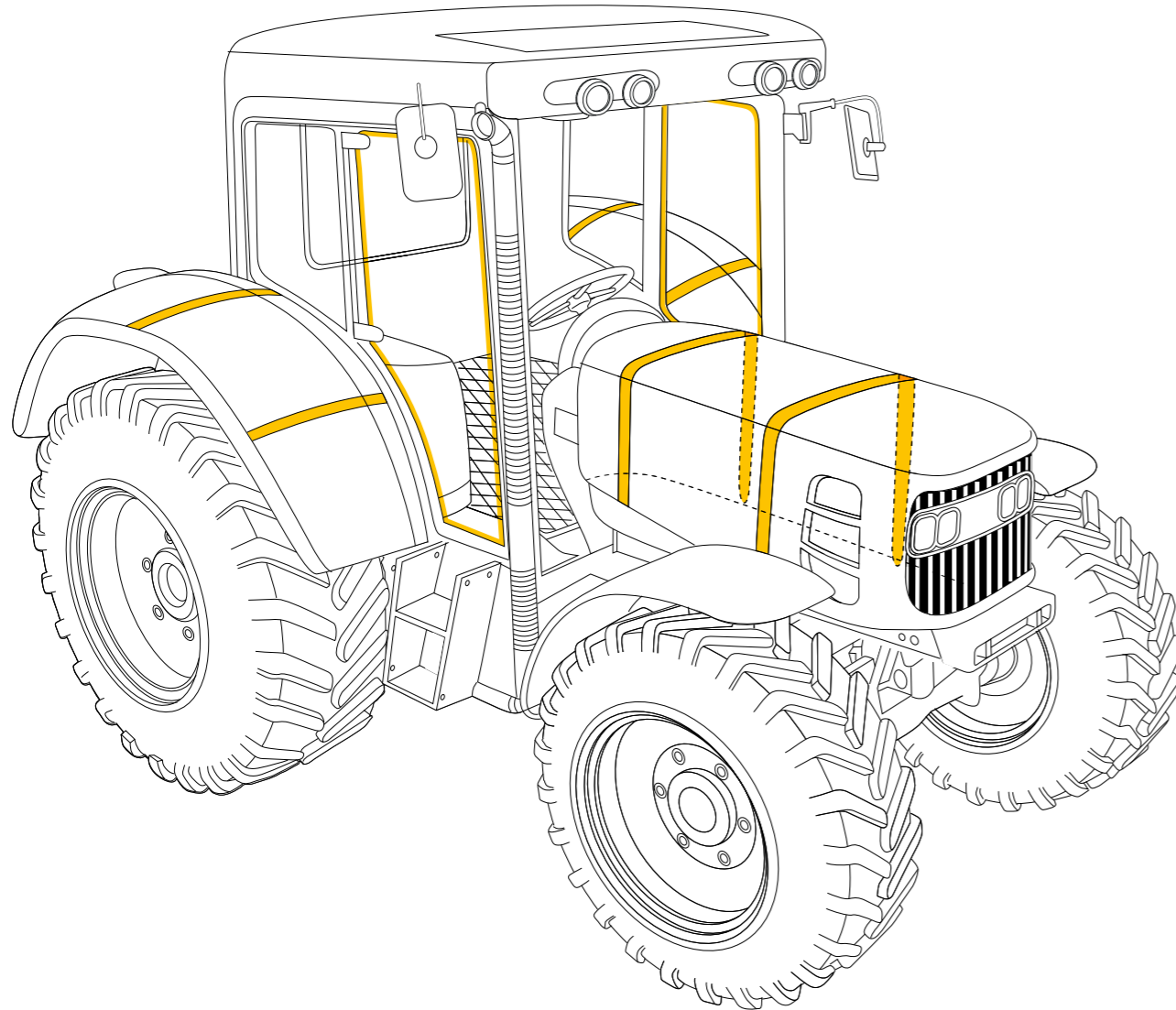

Doors, motor hoods and other parts of the finished vehicle must fulfil the same requirements as the primary cabin structure. Fast assembly of a high-strength structure and use metal or structural composite material is required. Reduction of the assembly process or the use of structural adhesives will provide the opportunities to achieve these targets.

Sika provides different solutions to support the customer in his efforts and endeavours. SikaPower® adhesives and sealants support the manufacturing of welding reduced parts, simply use the e-coat and paint process to fix it. SikaFast® two-component acrylic-based structural adhesives provide high strength and excellent impact resistance with low surface preparation. SikaForce® two-component PUR adhesives demonstrate high strength, good flexibility and are capable of curing at room or elevated temperatures. Sikaflex® polyurethane (PUR) adhesives and sealants provide a high-performance elastic assembly within an easy-to-use one-component formulation. Sikaflex® PUR-Hybrid, the silan terminated polymer (STP) technology, provides the high performance of Sikaflex® polyurethane systems combined with reduced substrate preparation and improved ecological benefits.



Sika®Power for door frame bonding

Why Use Structural Adhesives?

- Adhesive systems absorb vibration, improving interior and exterior vehicle noise levels
- Improved rigidity of the structure
- Lower vehicle weight
- Can withstand high dynamic stresses
- Bonded assemblies are more able to withstand shock, impact and torsion
- Elimination of contact corrosion

Technological Benefits

- Eliminates mechanical fixation
- Enhanced sound and vibration damping
- Rapid assembly with high-performance adhesion
- Excellent impact resistance
- Ability to withstand different CLTE (Coefficient of Linear Thermal Expansion) between thermoset composites and metals
- Bonds well to a wide variety of substrates
- Improved water and leak resistance
- Overpaintable

Best Recommended Sika Products

Features and Benefits

Sikaflex®-250 PC

Warm applied system; high green strength enables reduction in clips, fixings and tape; good tooling behaviour; widely OEM-approved; excellent adhesion characteristics

Sikaflex®-254 Booster

Fast curing; 'fail-safe' systems cures even in the absence of Sika® Booster Paste; good mechanical properties and adhesion

Sikaflex®-360 HC

Heat-curing high-performance structural adhesive and seam sealer with a long open and fast curing time

SikaPower®-415 P1

Excellent adhesion on oily substrates; heat cured; excellent seam-sealing properties

SikaPower®-430

Semistructural adhesive with excellent adhesion on oily substrates; heat cured; wash-out resistance; spot-weldable

SikaPower®-490/7

Structural adhesive for spot welding bonding with excellent adhesion on oily substrate, heat-curing and wash-out resistant

SikaFast®-3000 Series

High tensile properties, elasticity and impact resistance; excellent adhesion profile; gap-filling capability

SikaFast®-5000 Series

High mechanical properties; fast curing with long open times; excellent adhesion profile; low odour

SikaForce®-7550 Series

Two-component, high-strength elastic assembly adhesive



Bonded motor hoods ready for paint shop

Sika Worldwide

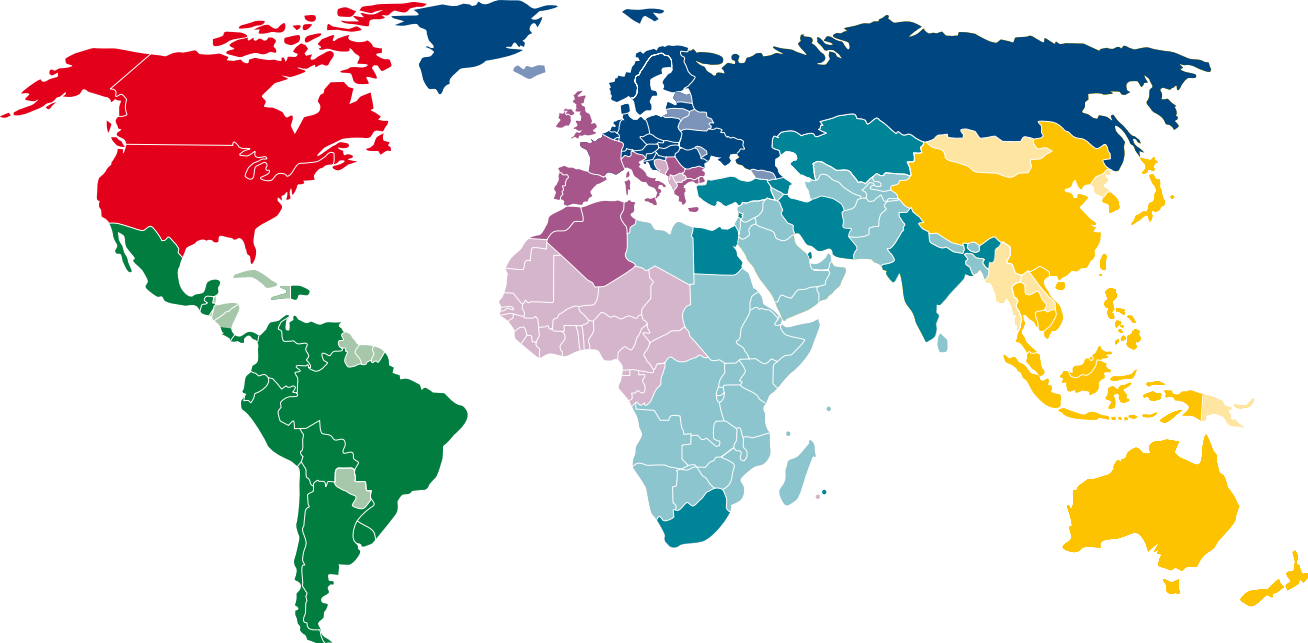

- 5 continents
- over 70 countries
- 90 production and marketing companies
- approx. 12,000 employees



Our most current General Sales Conditions shall apply. Please consult the most current local Product Data Sheet prior to any use.

www.sika.com

