

Industry

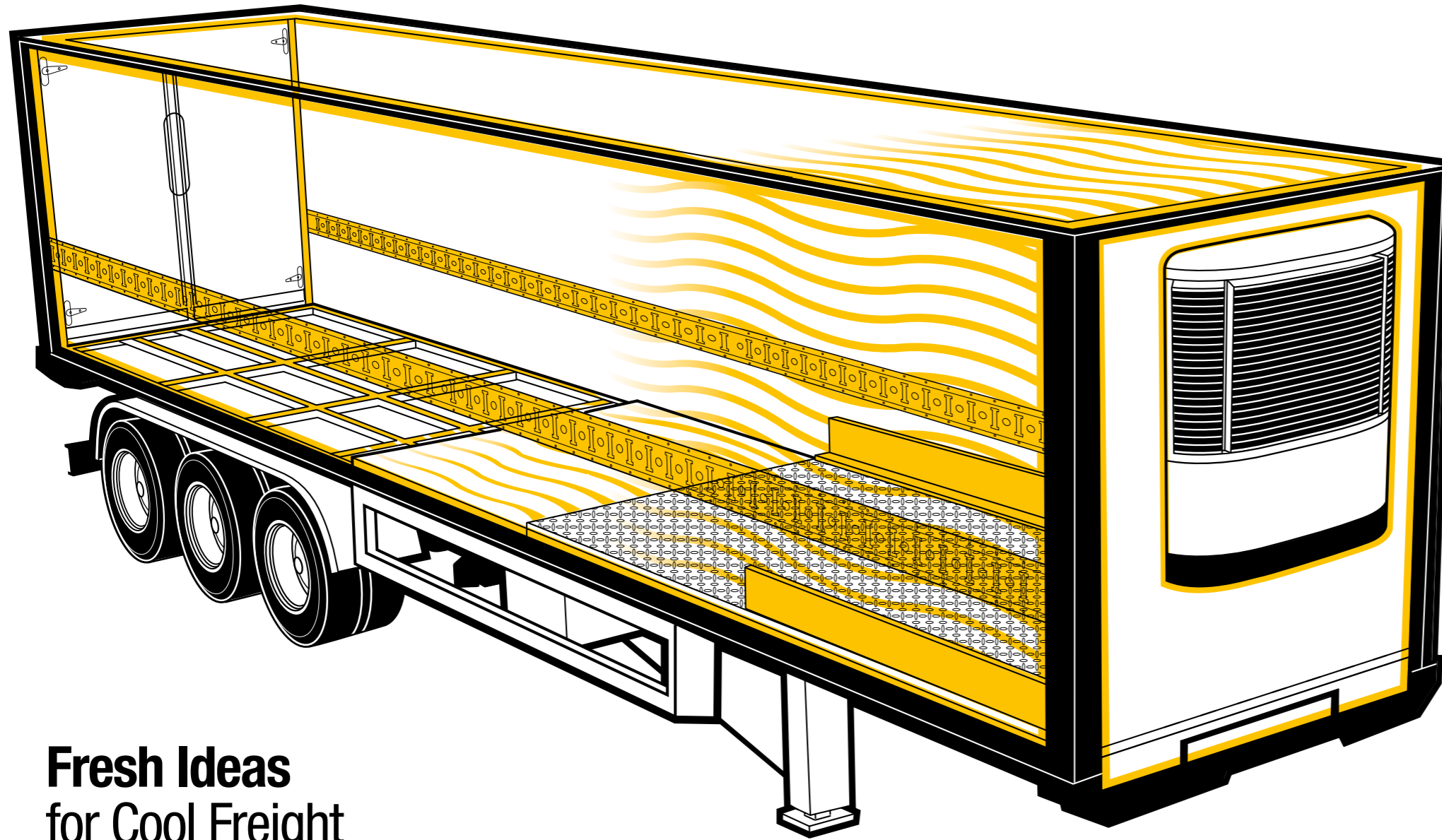

Refrigerated Trailers and Containers Fresh Ideas for Cool Freight

Sika®



Content

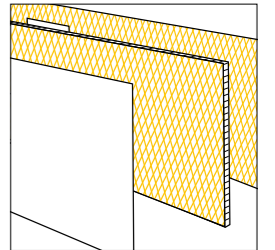

Sandwich Panel Production_4

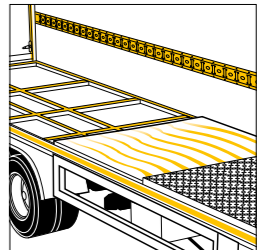

Assembly of the Body, Sealing and Bonding in Interior and Exterior_6

Fresh Ideas for Cool Freight

Users and owners of modern trailers, refrigerator vans and containers across the globe demand lightweight, durable vehicles which operate in an environmentally friendly way. In order to meet this challenge, manufacturers must constantly find new solutions that enable improved build times, increased rigidity and strength of the body, offering an optimum payload capability and extending the longevity of the product, and all while remaining competitive.

Sika, as the partner to the global trailer, refrigerator van and container manufacturer industry, provides a range of state-of-the-art technology solutions to assist manufacturers in meeting these challenges. As a specialty company for chemical products, we concentrate on our core competencies: Bonding, Sealing, Damping and Reinforcing. As a globally operating company, we are partners to our customers worldwide. Sika is represented with its own subsidiaries in all trailer, refrigerator van and container producing countries, thus ensuring first-class order handling, delivery, application development, and technical and commercial support.



Sandwich Panel Production

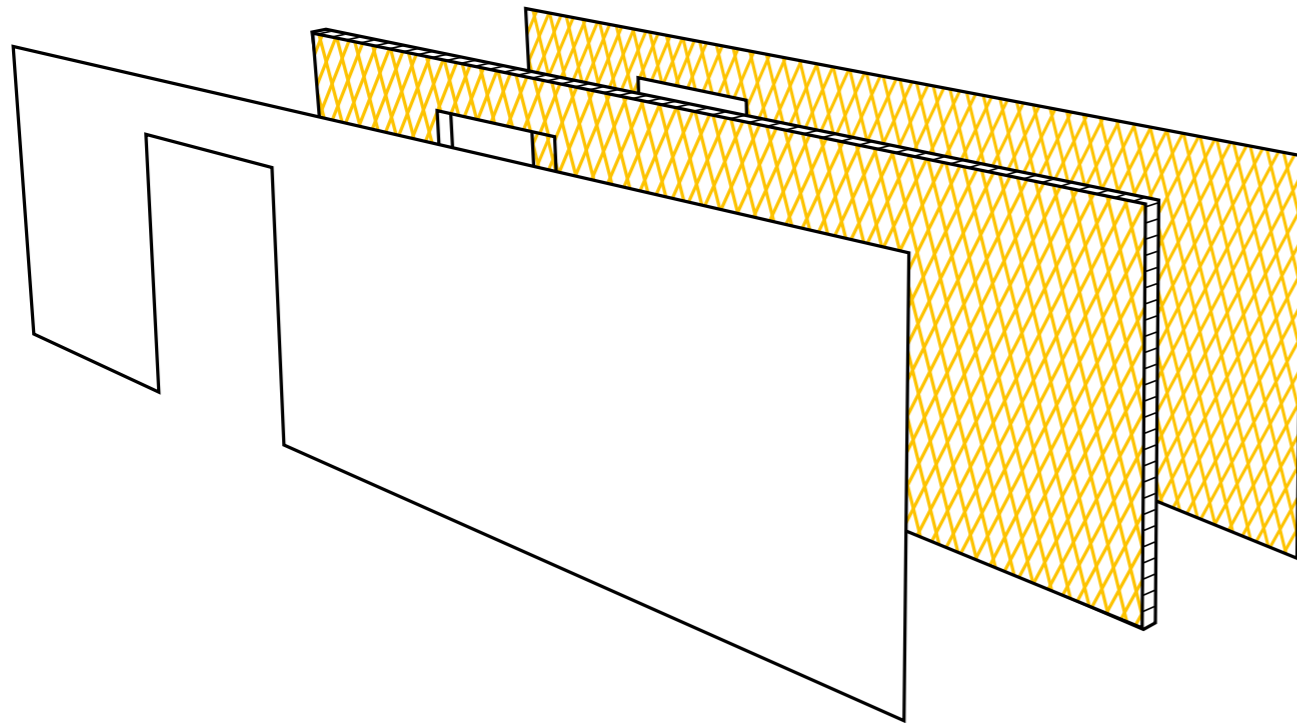

Trailer and container manufacturers use metal, wood, fibreglass and foam insulation in the production of side and rear walls, floors and roof structures. Increased efficiency in production is a critical factor for this competitive market place. Good thermal insulation and light-weight construction are required to provide enhanced performance and better fuel economy. The use of traditional fixing methods can result in buckling, deformation and denting of side and roof panels. Such issues require significant cost and labour to repair and rework. The use of adhesive bonding to fabricate the panels eliminates such risks and improves efficiency, quality and cost.

Sika provides solutions custom formulated to match with different customer process requirements. For example, systems are available with a wide range of press times, green strengths, open times and other key factors to adapt to the process needs of each customer's manufacturing requirements. We offer one- and two-component polyurethane (PUR) technologies (SikaForce®), as well as reactive hot-melt (RHM) technology (SikaMelt®), for such applications.



SikaForce® applied by spreader bar

Why Use Sandwich Panel Adhesive?

- Improved structural rigidity
- Lower panel weight, resulting in reduced total vehicle running costs
- Allows the use of high-performance foam cores to enhance thermal insulation
- Excellent water resistance
- Good process control, providing consistent and repeatable high-quality output
- Design flexibility

Technological Benefits

- Bonds well to a wide variety of substrates
- Faster production due to fast strength build-up
- Compatible with manual and automatic application processes
- Custom formulation to meet customer requirements
- Full range of technologies for sandwich panel assembly, including PUR lamination, hot-melt and reactive hot-melt systems

Best Recommended Sika Products

Features and Benefits

SikaForce®-7710

Two-component PUR adhesive with high strength, medium to long open and different press times for all types of lamination

SikaForce®-7715

Two-component PUR sandwich panel adhesive with the possibility of heat activation to reach very short press times

SikaMelt®-9600 Series

High green strength PUR hot-melt adhesives for sandwich panel production with different open times



Positioning of the core foam

Assembly of the Body, Sealing and Bonding in Interior and Exterior

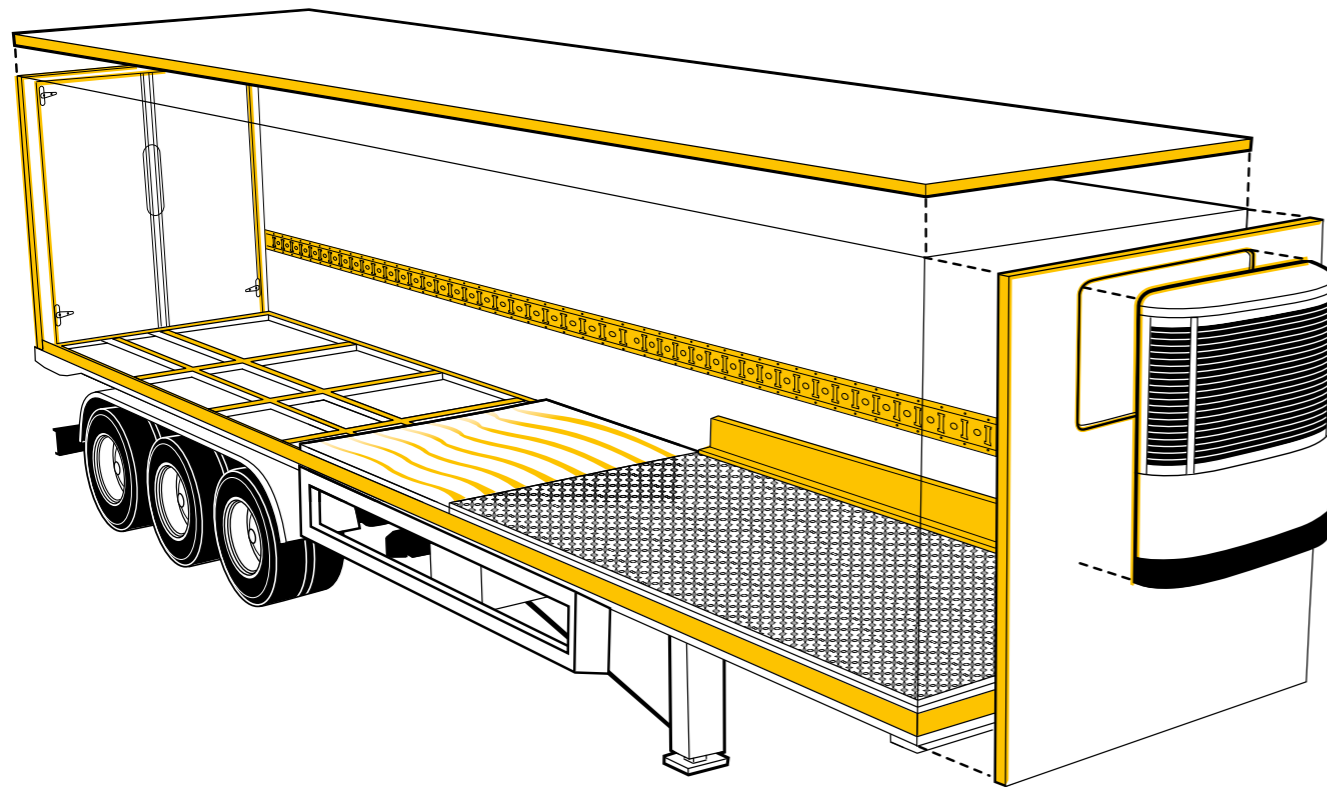

Recent years have seen dramatic changes in the styling and manufacturing of refrigerated trailers and containers. The mix of materials used to fabricate such equipment has also radically changed. The use of fibreglass composites and sandwich panel structures is now commonplace, as manufacturers seek to reduce vehicle weight, improve fuel economy, durability and enhance thermal insulation.

Sika can provide a range of high-performance solutions for body assembly. SikaForce® two-component PUR adhesives demonstrate high strength, good flexibility and are capable of curing at room or elevated temperatures. Sikaflex® polyurethane sealants and adhesives combine simplicity of application with excellent durability and adhesion. Sikaflex® PUR-Hybrid, silane terminated polymer (STP) technology, combines the performance of traditional Sikaflex® polyurethane systems, but demonstrates additional benefits such as reduced substrate preparation and improved worker safety. SikaFast® two-component adhesives combine low surface preparation and high tensile strength with rapid de-jigging and full cure.



Assembly of the box

Why Use Assembly Adhesives and Sealants?

- Higher rigidity of the structure without damage to thermal insulation – unlike mechanically fastened systems
- Lower weight, providing reduced running costs
- Excellent water resistance due to elimination of holes and drilling required by mechanical fasteners
- Improved aesthetics due to no visible fixings
- Reduced risk of warpage, as adhesives compensate for different thermal expansion rates between metal and nonmetal substrates
- Enhanced ability to withstand shock, impact and torsion

Technological Benefits

- Excellent balance of strength, flexibility and impact resistance
- Low thermal conductivity
- Excellent water resistance
- Wide range of cure speeds
- Superb adhesion to a wide range of substrates commonly used for trailer construction
- Suitable for automated or manual application
- Use of adhesives and sealants does not damage the vehicle corrosion protection layer, therefore reducing the likelihood of corrosion and repair work

Best Recommended Sika Products

Features and Benefits

Sikaflex®-221

High-quality multi-purpose sealant and adhesive, suitable for making permanent elastic seals of high adhesive strength

Sikaflex®-228

Self-levelling, low viscous, one-component polyurethane adhesive for panel bonding

Sikaflex®-252

Structural assembly adhesive for flexible joints subjected to dynamic stresses

Sikaflex®-254 Booster

Fast curing; 'fail-safe' systems cures even in the absence of Sika® Booster Paste; good mechanical properties and adhesion

Sikaflex®-521 UV

Joint sealant with excellent UV, ageing and weather resistance, reduced substrate surface preparation needed. Solvent and VOC-free

Sikaflex®-552

UV-stable assembly adhesive for sealing and bonding, excellent adhesion properties, ecology-friendly; suitable also for exterior joints

SikaFast®-3000 Series

High tensile properties, elasticity and impact resistance; excellent adhesion profile; gap-filling capability

SikaFast®-5000 Series

High mechanical properties; fast curing with long open times; excellent adhesion profile; low odour

SikaForce®-7720

High strength, non-sagging adhesive for all types of assembly applications

Sika Worldwide

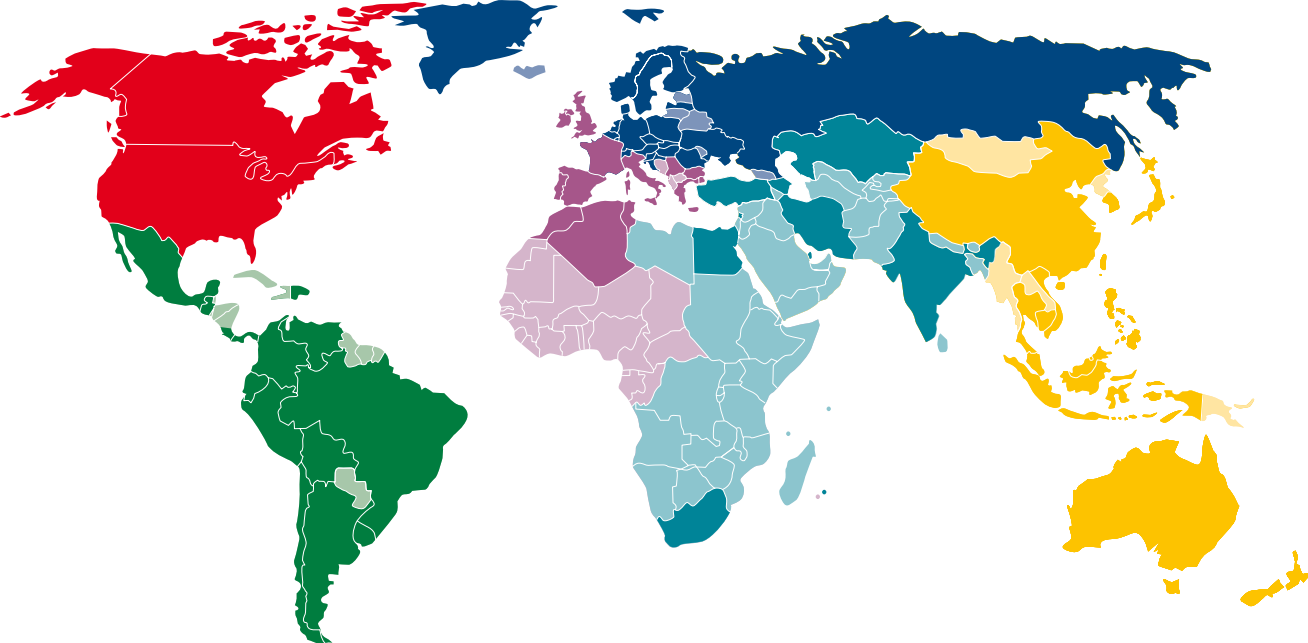

- 5 continents
- over 70 countries
- 90 production and marketing companies
- approx. 12,000 employees



Our most current General Sales Conditions shall apply. Please consult the most current local Product Data Sheet prior to any use.

www.sika.com

